



**DELTA**

**VRF BIG FAN COIL UNITS  
80AH SERIES**

**INSTRUCTION MANUAL**

**WARNING!**

Read and follow all safety precautions in Instruction Manual - improper use can cause serious injury.

## User Notice

Thank you for choosing DELTA□□ air conditioner, please read this manual carefully before using this unit and operates it correctly according to guideline in this manual, and keeps it for reference.

- ◆ When the unit is operating, the total capacity of the indoor units should be no more than the capacity of outdoor unit, otherwise, it can cause the shortage of cooling capacity (heating capacity) of each indoor unit.
- ◆ The power supply of the indoor unit must be the unified power supply. The indoor unit cannot have the individual power switch, and the entire indoor unit can only be controlled by one main power control. Disconnect the main power of all the indoor units before cleaning.
- ◆ In order to start the unit successfully, the general power supply switch of the air-conditioning units should be turned to the "ON" position for 8 hours before running.
- ◆ After each of indoor units received the stop running signal, the fan motor of the indoor unit will use the surplus cool or surplus heat of the heat exchanger go on running for 20-70 seconds, this is the preparation for the next time use and this is the normal phenomenon.
- ◆ When the selected mode of the indoor unit conflicts with the mode of outdoor unit, after 5 seconds, the wired remote control will display the operation conflict, the indoor unit will stop running, then to unify the running modes of the indoor unit and outdoor unit, the unit will get right. There is no conflict in the COOL mode and DRY mode, the FAN mode will not conflict with any other modes.
- ◆ The appliance shall not be installed in the laundry.
- ◆ An all-pole disconnection switch having a contact separation of at least 3mm in all poles should be connected in fixed wiring.
- ◆ Missing information regarding electric supply tolerances(+/-10%, +/-1Hz) in documentation.
- ◆ Missing information regarding humidity (30-95%) in documentation.
- ◆ Missing information regarding installation altitude (max 1000m) in documentation.
- ◆ Information regarding transport/storage temperature (-25-55°C) is missing.
- ◆ Main switch provided by end user: main switch handle should be black or gray, it can be locked in "OFF" position with padlock.
- ◆ The main disconnection device should be explained in user manual and the height should be recommended at 0.6-1.7m. over current protection is required(EN 60947-3, EN 60947-2).
- ◆ The cooling range of the unit is the outdoor environment temp.18-43℃ DB, the heating range of the unit( only for the heat pump type unit) is the outdoor environment temp. -16-15℃ WB.
- ◆ This appliance is not intended for use by persons (including children) with reduced physical, sensory or mental capabilities, or lack of experience and knowledge, unless they have been given supervision or instruction concerning use of the appliance by a person responsible for their safety.



This mark indicates that this product should not be disposed with other household wastes throughout the EU. To prevent possible harm to the environment or human health from uncontrolled waste disposal, recycle it responsibly to promote the sustainable reuse of material resources. To return your used device, please use the return and collection systems or contact the retailer where the product was purchased. They can take this product for environmental safe recycling.

## Contents

1. SAFETY PRECAUTIONS.....	1
2. THE SELECTION OF INSTALLATION PLACE AND NOTICE OF THE AIR CONDITIONER.....	2
2.1 Installation Location of the Air Conditioner .....	2
2.2 Installation Location of the Indoor Unit .....	2
2.3 The Electric Cord Disposal .....	2
2.4 Earthing Requirement .....	3
2.5 Accessories for Installation.....	3
3. INSTALL OF THE DUCT TYPE INDOOR UNIT .....	3
3.1 Dimension Diagram of Indoor Unit .....	3
3.2 Schematic Diagram of Installation Spaces .....	4
3.3 Installation of Condensate Pipes.....	6
3.4 Design of the Drain Pipe .....	6
3.5 Testing on the Drainage System.....	6
3.6 Functional DIP Switch S7 .....	7
3.7 Address DIP Switch .....	8
3.8 Usage of Remote Receiver .....	9
3.9 Install the Wired Remote Controller .....	10
3.10 Installation Notice .....	11
3.11 Wiring between the Wire and the Wiring Terminal .....	11
3.12 Connection of Distribution (Communication) Wires:.....	12

3.13 Connection of Power Cord: .....	12
3.14 Wiring of the Signal Line of the Wired Controller .....	14
4. NAME AND FUNCTION OF EACH PART OF DUCT TYPE	
INDOOR UNIT .....	14
5. WORKING TEMPERATURE RANGE .....	15
6. TROUBLE SHOOTING .....	15
7. CARE AND MAINTENANCE .....	16
7.1 Daily Care.....	16
8. THE PARAMETER LIST OF DUCT TYPE INDOOR UNITS .....	16

# 1. SAFETY PRECAUTIONS

(1). Before using the appliance, read this manual thoroughly and operate under its direction.

(2). "WARNING" and "ATTENTION" have the following meanings in this instruction:

 **WARNING!**: This mark indicates procedures, which if improperly performed, might lead to death or serious injury of the users.

 **ATTENTION!**: This mark indicates procedures, which if improperly performed, might possibly result in personal injury to the user, or damage to property.

 **WARNING**

- ◆ When install the unit, please refer to the special arrangement maintenance center. If improperly performed, it may cause the water leakage, electric shock or fire accidents etc.
- ◆ Please install the unit at a steady and stable place. If the strength is inadequate, the unit will fall off and lead to personal injury or death.
- ◆ The drain pipe should be installed as instructed in the manual to guarantee the proper drainage; meanwhile it should be insulated to prevent condensing; otherwise the improper installation would cause water leakage and then wet the household wares in the room.
- ◆ Do not use or store any inflammable, combustible or any noxious substance next to the unit.
- ◆ When malfunction happens (like burning smell etc.), please immediately cut off the general power supply of the units.
- ◆ Keep good ventilation in the room to avoid oxygen deficit.
- ◆ Do not insert hands or other objects into the inlet or outlet grille.
- ◆ Due to the long time use, please check the mounting frame if broken or not.
- ◆ Never refit the unit and please contact the sales agent or the professional installation personnel for the repair or relocation of the unit.

 **ATTENTION!**

Ensure the power supply corresponds to the nameplate and check the security of the power source before installation.

- ◆ Make sure that the wires, pipes and drain hose are properly connected before operation to avoid fire or electric shock.
- ◆ The general power supply must be reliably earthed to avoid the electric shock. Please do not connect the ground wire to gas pipe, water pipe, lightning rod or telephone line.
- ◆ Turn off the unit after it runs at least five minutes; otherwise it will influence oil return of the compressor.
- ◆ Don't allow children to operate the units.
- ◆ Do not operate the units with wet hands.
- ◆ When cleaning the air conditioner or changing filters, please turn off the general power supply of the units firstly.
- ◆ Switch off power source when the units will not be operated for a long period.
- ◆ Do not expose the unit to the moist or corrosive circumstances.
- ◆ After the unit is electrified, please check if there is any electric leakage.

## 2. THE SELECTION OF INSTALLATION PLACE AND NOTICE OF THE AIR CONDITIONER

### 2.1 Installation Location of the Air Conditioner

The installation must accord with the national and local safe criterion.

Since the quality of installation would affect the operation directly, user should contact the seller and have the conditioner installed and tested by the professional installation personnel according to the install instruction instead of install by himself/herself.

Only connect the power after all the installation works are finished.

### 2.2 Installation Location of the Indoor Unit

- (1). Never expose the unit directly to sunlight.
- (2). Make sure that the ceiling is strong enough to bear the weight of the unit.
- (3). The drainage pipe is easy to drain.
- (4). The air flow is not blocked at the air outlet and inlet.
- (5). The connecting pipe between indoor and outdoor units can be led to outside conveniently.
- (6). The unit cannot be installed in a place where is next to inflammable, combustible or any noxious substance.
- (7). The unit cannot be installed in a place where has the corrosive gas and serious dust, saline fog, lampblack and heavy humidity.
- (8). The installation height of the main body should be 2.5m or more.



Note!

The unit installed in the following places is likely to run abnormally. If unavoidable, please contact the professional personnel at the DELTA□□ appointed service center① where is full of oil; ② alkaline soil off the sea; ③ where there is sulfur gas (like sulfur hot spring); ④ where there are devices with high frequency (like wireless devices, electric welding devices, or medical equipments); ⑤ special circumstances.

### 2.3 The Electric Cord Disposal

- (1). The cord disposal should be installed according to the national regulations.
- (2). The power must use the rated voltage and the exclusive electric circuit for air conditioner.
- (3). Please don't pull the power cord forcibly.
- (4). All the electric equipment should be installed by the professional personnel according to the local law, regulation and this instruction.
- (5). The power cord diameter should be large enough; the destroyed power cord and connecting cord should be replaced by the specific cord.
- (6). The earthing should be reliable and the earth wire should be connected to the dedicated device of the building by the professional personnel. Besides, the air switch coupled with the leakage current protection switch must be equipped, which is of enough capacity and of both magnetic and thermal tripping functions in case of the short circuit and overload.

## 2.4 Earthing Requirement

- (1). The air conditioner is classified into the Class I appliances, so its earthing must be reliable.
- (2). The yellow-green line of the air conditioner is the earth line and can not be used for other purpose, cut off or fixed by the tapping screw; otherwise it would cause the hazard of electric shock.
- (3). The earth resistance should fit the requirement of the national standard GB17790.
- (4). The reliable earth terminal should be provided and the earth wire can not be connected to any of the following place.

① Tap water pipe; ② Gas pipe; ③ Sewage pipe; ④ Other places where the professional personnel think unreliable.

## 2.5 Accessories for Installation

Refer to the packing list for the accessories of the indoor and outdoor units respectively.

## 3. INSTALL OF THE DUCT TYPE INDOOR UNIT

### 3.1 Dimension Diagram of Indoor Unit

The dimensions of installation hole and the intake/outlet port are shown in Fig. 1 and Table 1.

The following figure is applicable to the indoor units of 80AH080J24 & 80AH100J24.

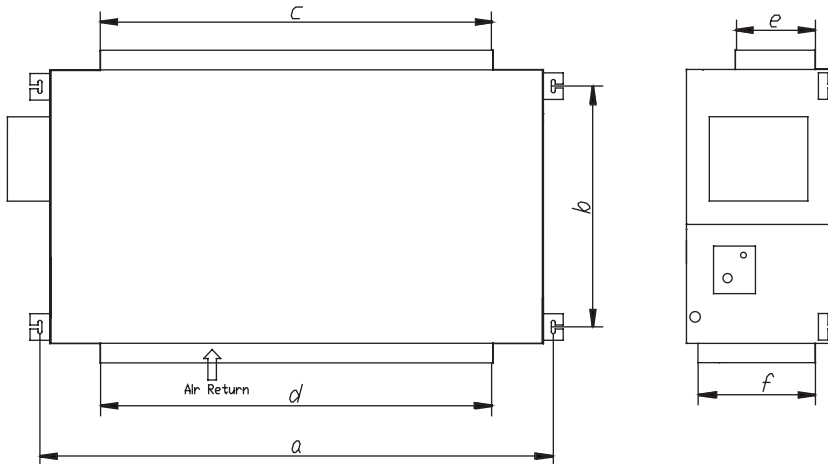

Fig. 1

In front of the air outlet, the wiring is at the right of the unit.

Table 1

Model	a	b	c	d	e	f
80AH080J24	1563	706	992	1350	192	402
80AH100J24						

### 3.2 Schematic Diagram of Installation Spaces

#### (1). Main body of the indoor unit

The indoor unit should be installed horizontally and the demand of installation space is shown in Fig. 2. To install an indoor unit requires 4 suspenders, and each suspender should at least withstand four times of the unit's weight.

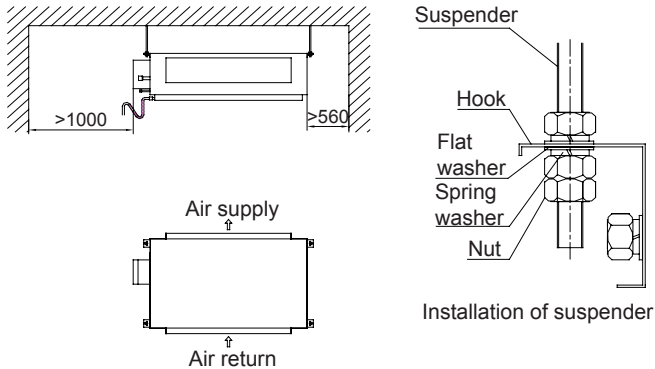

Fig.2

#### (2). Drain hose

For easy drainage of the condensate, the unit should be installed with a downward gradient. To avoid the condensation, the connection pipe joint should be insulated with thermal insulation material. A water seal should be employed as shown in Fig. 3 and the height of the water seal should be determined by the pressure of the drain hose.

Drain hose is in negative pressure state:  $A = B \geq P/10 + 20$  (mm).

Drain hose is in positive pressure state:  $A \geq 30\text{mm}$ ;  $B \geq P/10 + 20$  (mm).

Note: P is the absolute pressure of the drain hose position, Pa.

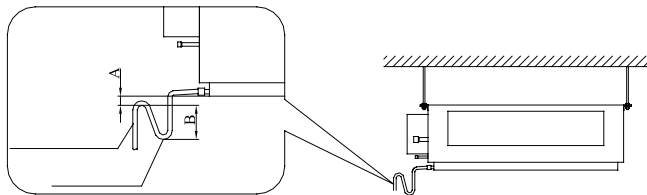

Fig.3

#### (3). Insulation for refrigerant pipe

To avoid condensation and water leakage, gas pipe and liquid pipe should be insulated with thermal insulation material and adhesive tape.



(4). Install the electric box

In order to facilitate the service work, we recommend to get the electric box part out of the indoor unit to reset it at the air outlet. Please see following Fig 4.

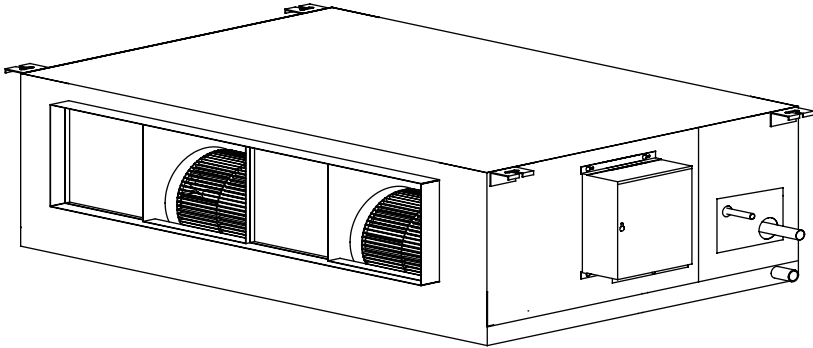

Fig. 4 Schematic for the electric box part



Attention:

- ◆ There should be thermal insulation layers around the air supply and air return ducts as well as on the new air ducts to protect against heat losses and condensation. Adhere the plastic nails onto the ducts, and then attach a layer of insulation cloth with the tinfoil onto the ducts. Fix the plastic nail and then seal tightly the joints by way of tinfoil tapes. Some other materials with good thermal insulation properties can also be used.
- ◆ The air supply and air return ducts should be fixed to the prefabricated ceiling boards with iron stands. The joints of the air ducts should be sealed tightly to prevent from air leakage.
- ◆ The design and operation of the air ducts should comply with the related state standards and procedures for engineering.
- ◆ It is recommended to leave at least a space of 150mm between the edge of the air return duct and the wall, and a filter screen should be placed at the air return opening.
- ◆ Muffling and vibration reduction should be taken into consideration during the designing and operation of the air ducts. In addition, the noise source should be kept away from the crowds. It is absolutely not allowed to design the placement of the air return opening right above the head of the users (in the offices, lounges or other public sites).

### 3.3 Installation of Condensate Pipes

The condensate pipes should be kept at 5—10 degrees of gradient to facilitate discharge of the condensate. Thermal insulation materials should be wrapped at the joints of the condensate pipes so as to prevent from condensation. (As shown in Fig.5)

Thermal insulation layer of the condensate pipe

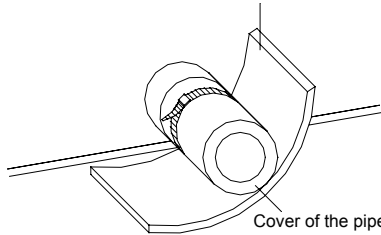

Fig.5 Thermal insulation of the condensate pipe



Attention: Confirm that there is no leakage at the joints of the condensate pipes.

### 3.4 Design of the Drain Pipe

- (1). The drain pipe should always keep an inclination angle( $1/50\sim 1/100$ ) to avoid the water gathering in some certain place.
- (2). During the connection of the drain pipe and device, do not impose too much force on the pipe on one side of the device and the pipe should be fixed as close as to the device.
- (3). The drain pipe can be the ordinary hard PVC pipe which can be purchased locally. During the connection, inset the end of the PVC pipe to the drain outlet, then tighten it with the drain hose and binding wire but never connect the drain outlet and the drain hose by adhesive.
- (4). When the drain pipe is used for multiple devices, the public section of the pipe should be 100mm lower than the drain hole of each device and it is better to use the much thicker pipe for such a purpose.

### 3.5 Testing on the Drainage System

- (1). Upon completion of the installation of the electric appliances, the testing on the drainage system should be performed.
- (2). During the testing, check if the water flows through the pipeline in the correct direction and make sure that there is no water leakage of at the pipe joints.
- (3). When the unit is intended to be installed in a new building, it is recommended that the testing should be taken prior to the decoration of the ceiling.

### 3.6 Functional DIP Switch S7

- (1). Before powering on of the main board, 5-bit DIP switch must be set to determine running status of indoor unit.
- (2). Function description is shown as below:

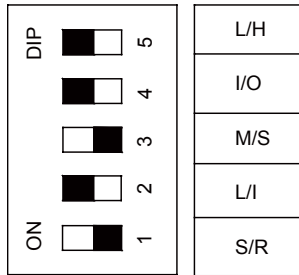

Fig.6

The DIP switch setting shown in above illustration is the default setting before outgoing.

Table 2

DIP switch	Function Description	ON	OFF
1(S/R)	Selection of memory mode: A. Selection between recovery mode and standby mode after power on B. This function is invalid when the wired controller is used.	Standby after power on	Recovery after power on
2(L/I)	Selection between receiver and wired controller: A. If wired controller is selected; remote-control function of receiver will be shielded. B. If receiver is selected, wired controller will be invalid.	Select wired controller to operate	Select receiver to operate
3(M/S)	Setting of master unit and slave unit A. This function is used to solve mode conflict. B. This function is invalid when the wired controller is used.	Master unit	Slave unit
4(I/O)	Selection of ambient temp. sensor: A. Selection between ambient temp. sensor (T amb.) of main board and that (T amb.1) of receiver B. This function is invalid when the wired controller is used.	Select ambient temp. sensor of main board	Select ambient temp. sensor of receiver
5(L/H)	Select to choose high E.S.P or low E.S.P fan speed	Select low E.S.P fan speed	Select high E.S.P fan speed

Notes:

- ◆ When you choose to equip the remote receiver (optional) on the units, it is required that set the 2nd position of S7 DIP switch to OFF position, meanwhile if need to plug the communication cable from remote receiver into 9-core terminal CN20 which located on the mainboard, and wired remote controller is invalid.
- ◆ When you choose to equip wired remote controller to the units, it is required to set the 2nd position of S7 DIP switch to the ON position, and connect 4-core communication cable to CN19 terminal on the mainboard; the address code on wired remote controller and indoor mainboard **MUST BE THE SAME**, after doing this, the remote receiver is invalid.

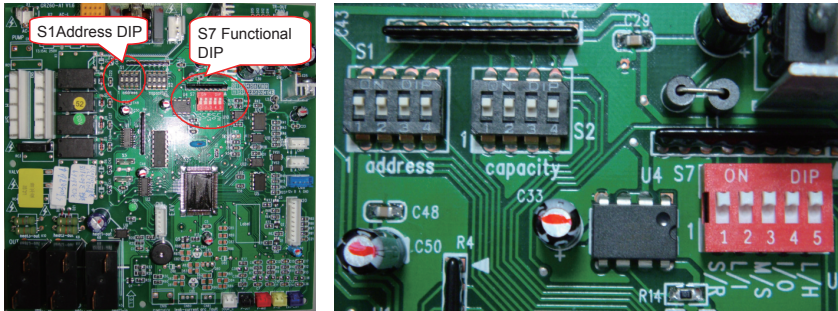
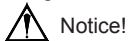

Fig.7 5-bit functional DIP switch mainboard

### 3.7 Address DIP Switch

All the indoor units of VRF system must set the address code properly; otherwise it will cause abnormal communication between outdoor and indoor units. There are total 4-bit address codes with range from 1 to 16.



Notice!

When more than 1 indoor unit is connected in parallel, please modify the address code of the units before installation, their address code should be different from each other. (Address code DIP switch located on the main board of indoor units); if adding wired remote controller to the unit, make sure the address code on controller is the same as on the indoor unit. (Address code DIP switch of wired remote controller located at the back of the controller)

(1). the default setting of DIP address setting is shown as below:

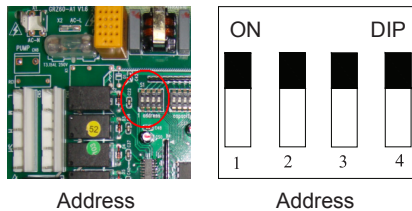

Fig.8

Default setting of DIP switch is 0000 which represents address is 1 (position shown as above).

(2). Address code list

The address code setting is based on binary. The “ON” side represents 0, while the opposite

side

represents 1. On address code DIP switch, there are 4 positions, 4 position represents high side and 1 position represents low side.

Table 3

Address	1				2				3				4				5				6				7				8											
DIP position	1	2	3	4	1	2	3	4	1	2	3	4	1	2	3	4	1	2	3	4	1	2	3	4	1	2	3	4	1	2	3	4	1	2	3	4				
Set value	0	0	0	0	1	0	0	0	0	1	0	0	1	1	0	0	0	0	1	0	1	0	1	0	0	0	1	1	0	0	1	1	0	1	1	0				
Address	9				10				11				12				13				14				15				16											
DIP position	1	2	3	4	1	2	3	4	1	2	3	4	1	2	3	4	1	2	3	4	1	2	3	4	1	2	3	4	1	2	3	4	1	2	3	4	1	2	3	4
Set value	0	0	0	1	1	0	0	1	0	1	0	1	1	1	0	1	0	0	1	1	1	1	1	1	1	0	1	1	0	1	1	1	0	1	1	1				

e.g.1: Set DIP switch as “0111” which represents address “8”. Set DIP switch 1,2,3 position to OFF side, while set 4 position to ON side;

e.g.1: set DIP switch as “1010” which represents address “11”. Set DIP switch 2,4 position to OFF side, while set 1,3 position to ON side.

Example shown as below:

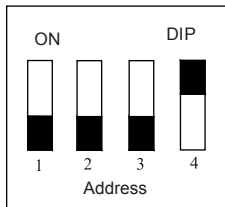

Fig.9 Address 8: DIP value 0111

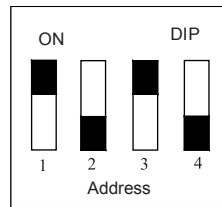

Fig.10 Address 11: DIP value 1010

### 3.8 Usage of Remote Receiver

When the remote receiver is adopted, set 2nd position on the S7 functional DIP switch to the “OFF” side, then connect the remote receiver to the main board.

For duct type indoor units, there are two options: work with remote receiver or wired remote controller; if the remote receiver is used, the wired controller can not be put into effect at the same time.

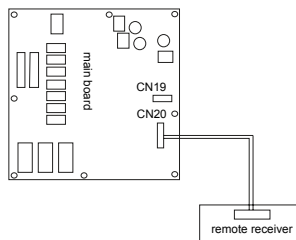

Fig.11 Connection between main board and remote receiver

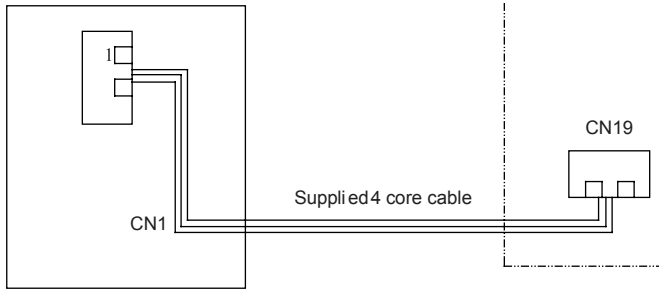

Fig.12 Power/communication wiring illustration of wired remote controller

When connect wired controller to main board showed as Fig.12, use a 4-core cable to set up a communication wiring from CN19 terminal on the main board to CN1 terminal on the wired controller. Make sure the power is shut off before the wiring; check if the wiring is properly connected and prevent any short circuit after finishing this step one more time. There are 4 pieces of wires in the cable of controller (all included in the 4-core cable). Count from upper right direction of wiring terminal are the name of the wires: earth wire (GND), communication wire A (A), communication B(B), power wire (+12V)

### 3.9 Install the Wired Remote Controller

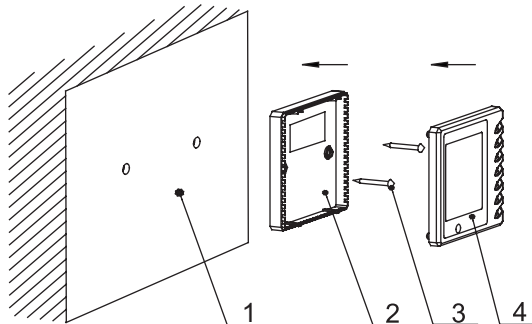

Fig.13 Installation of wired remote controller

Table 3

SN	1	2	3	4
Name	Casing base, installed into the wall	Controller Soleplate	Screw M4X25	Controller Panel

Table 4 Dimensions of the Refrigerant Pipe

	80AH080J24 & 80AH100J24
Gas Pipe	Φ22.2 L=15 Brazing
Liquid Pipe	Φ9.52 L=10 Brazing

### 3.10 Installation Notice

- (1). Cut off power supply before install the electrical components, it is forbidden to carry out the installation with power on. (See Fig.13)
- (2). Get one end of the 4-core communication cable, put it through the rectangular hole on the base board on the wire remote controller;
- (3). Fix the base board of controller on the wall with M4x25 screw;
- (4). Plug the 4-core communication cable into the slot on the wired remote controller, then fix the controller panel with base board together.

### 3.11 Wiring between the Wire and the Wiring Terminal

#### (1). Connection of solid wire

- 1). Use a wire stripper to strip off about 25mm of the insulation layer at the end of the solid wire;
- 2). Remove the screws on the terminal board of the air conditioner;
- 3). Use the pliers to bend the end of the wire into a loop suitable for the terminal screw;
- 4). Pass the screw through the wire ring and fix it onto the terminal board.

#### (2). Connection of strand wire

- 1). Use the wire stripper to strip off about 10mm of the insulation layer of the strand wire;
- 2). Remove the screws on the terminal board of the air conditioner;
- 3). Use the wire pliers to press the ends of the strand wire onto the terminals corresponding to the size of the screws;
- 4). Pass the screws through the terminals of the strand wire and fixes them onto the terminal board.

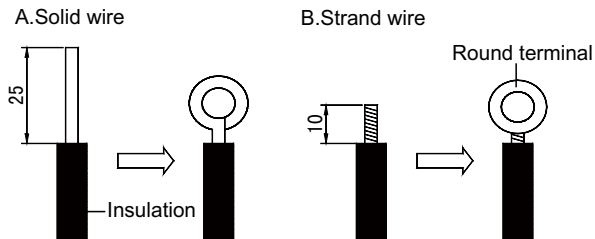

Fig.14

#### Warning:

- ◆ If the power cord or signal cord of the unit is damaged, special-purpose cords must be used for replacement;
- ◆ Please identify the voltages for the components indicated on the nameplate before doing the wire connection, and then connect the wires in accordance with the schematic diagram of wiring.
- ◆ The air conditioner should use the special-purpose power cord and should be equipped with air switch so as to handle the occurrence of overload;
- ◆ The air conditioner must be properly grounded to prevent from the damages caused by the failure of insulation;

- ◆ All the distribution wires must use the press-connecting terminals or single wires. The direct connection between the multi-ply stranded wires and the terminal board might lead to sparking;
- ◆ All the wiring must follow the schematic diagram for the electric circuits. Any erroneous wiring and connection might result in the abnormal operations or damages of the air conditioner;
- ◆ Do not allow the power cord to contact the pipelines or any moving parts like the compressor or fan;
- ◆ The internal wiring of the air conditioner should not be altered without authorization. The manufacturer shall not be responsible for any losses or abnormal operations incurred from such unauthorized alterations.

### 3.12 Connection of Distribution (Communication) Wires:

- (1). Open the cover of the electric box of the indoor unit;
- (2). Pass the distribution (communication) wire through the rubber gasket;
- (3). Insert the distribution (communication) wire into the 3-pin socket of CN17 or CN18 on the electric circuit board of the indoor unit;
- (4). Bundle the distribution (communication) wires firmly and fix them well.

### 3.13 Connection of Power Cord:



Attention:

- ◆ The power supply for various indoor units must be from the unified power supply.
  - ◆ According to Clause 7.12.2 of IEC/EN 60335-1, the wiring of the unit should be in accordance with the national and local wiring rules.
- (1). Air conditioning units using single-phase power supply
    - 1). Remove the cover of the electric box of the indoor unit;
    - 2). Pass the power cord through the rubber gasket;
    - 3). Connect the power cord to the L and N terminals as well as the grounding screw;
    - 4). Fix the signal line with the binding wire.
  - (2). Power cord standard and air switch parallel table

Model	Air switch capacity (A)	Min. sectional area of power cord(mm <sup>2</sup> )
80AH080J24	6	1.5
80AH100J24	6	1.5

Note: The specification of power cord mentioned hereby is defined as the required specification when wiring with BV single-core cable (2~4 pieces) under the cover of PVC pipe, and environment temperature shall be at 40°C. Air switch shall be selected according to 40°C temperature condition with "D" type. If the installation condition changes, please consider the modification on the required specification of power cord and air switch, according to the specification manual provided by manufacture.



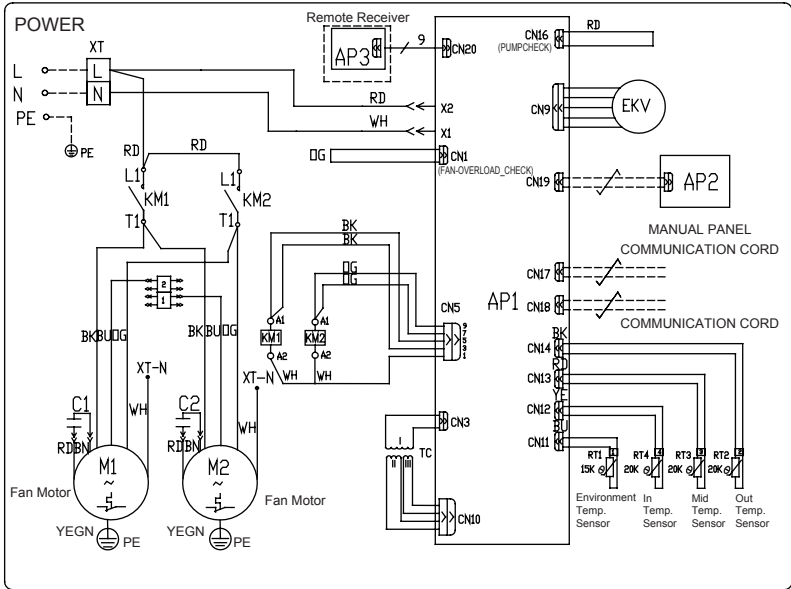

80AH080J24 Schematic Diagram of Electric Wiring

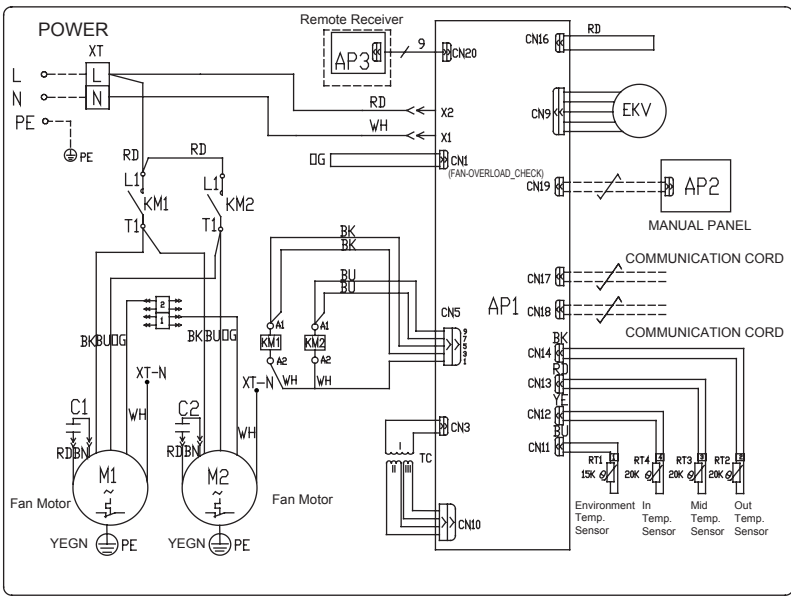

80AH100J24 Schematic Diagram of Electric Wiring

### 3.14 Wiring of the Signal Line of the Wired Controller

- (1). Open the cover of the electric box of the indoor unit;
- (2). Pass the signal line of the remote controller through the rubber ring;
- (3). Insert the signal line to the four-pin socket (CN19) on the printed circuit board of the indoor unit;
- (4). Fix the signal line with the binding wire.



#### Attention:

Special precaution must be taken when doing the following connections so as to prevent from the failure of the air conditioner due to EMI (electromagnetic interference).

- ◆ The signal lines and the distribution (communication) wires should be separated from the power supply cord and the connection lines between the indoor and the outdoor units;
- ◆ In the case that the air conditioner has to be installed at the places subject to the EMI, it is advised to use shielded and double-strand wires for the signal lines and distribution (communication) wires.

## 4. NAME AND FUNCTION OF EACH PART OF DUCT TYPE INDOOR UNIT

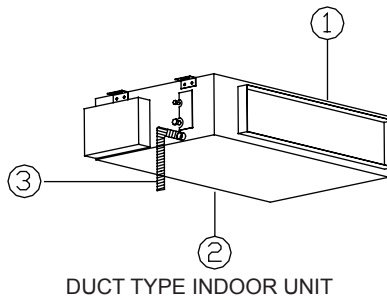

- ① . Air Outlet;
- ② . Air Inlet;
- ③ . Condensate Pipe.

**NOTE: Connection pipe and gas pipe are not included in this air conditioner.**

## 5. WORKING TEMPERATURE RANGE

Table 5 Working Temperature Range

	Indoor side state	
	Dry bulb temp. °C	Wet bulb temp. °C
Rated Cooling	27	19
Max. Cooling	32	23
Min. Cooling	21	15
Rated Heating	20	15
Max. Heating	27	—
Min. Heating	20	15

## 6. TROUBLE SHOOTING

Note: If the malfunction occurs, please check the following items shown below before contacting service center.

Table 6

Phenomenon	Cause
The unit can't start.	<ol style="list-style-type: none"> <li>1. The power supply is not connected well.</li> <li>2. The electrical leakage protection is tripped off.</li> <li>3. The voltage is too low.</li> </ol>
The unit stops soon after it starts.	The inlet/outlet is clogged.
The cooling effect is not good.	<ol style="list-style-type: none"> <li>1. The air filter is dirty or clogged.</li> <li>2. There are heat sources in the air-conditioning room or too many people in this room.</li> <li>3. The door or window is opened.</li> <li>4. There are obstructions in the air inlet or outlet grille.</li> <li>5. The setting temp. is too high, which will affect the cooling effect.</li> </ol>
The heating effect is not good.	<ol style="list-style-type: none"> <li>1. The air filter is too dirty or clogged.</li> <li>2. The door or window isn't closed well.</li> <li>3. The setting temp. is too low, which will affect the heating effect.</li> </ol>
The remote controller can not work.	<ol style="list-style-type: none"> <li>1. Recover the remote controller by removing the rear cover and press "ACL"(reset key).</li> <li>2. Is it within the receiving range? Or are there any obstructions?</li> <li>3. For the duct type indoor unit, operate the wireless remote controller pointing at the wired remote control.</li> <li>4. Replace the batteries if the voltage is too low.</li> </ol>

#### NOTE:

If the air conditioner still runs abnormally after the above check and handling, please turn off the unit immediately and contact the local service center and ask the professional personnel for help.

## 7. CARE AND MAINTENANCE



**ATTENTION:** Please pay more attention to the following items before cleaning the units. The general power supply of the indoor units must be powered off before contacting the wiring device;

Only when the unit is turned off and the general power supply is cut off, the unit could be cleaned, otherwise it might cause the electric shock or injury;

Do not use water to clean air conditioners, or it may cause electric shock;

Especially when cleaning the units you should pay more attention, to stand on the firm place.

### 7.1 Daily Care

(1). Clean the air filter

- 1). When not cleaning the air filter, please do not disassemble the filter, otherwise it will cause malfunction.
- 2). When there is a lot of dust, the air filter should be cleaned more frequently (generally once for every two weeks).

(2). Check before the seasonal use

- 1). Check if the inlet/outlet of the indoor/outdoor unit is clogged.
- 2). Check if the earth lead is earthed reliably.
- 3). Check if the wiring is connected soundly.
- 4). After switching on, the indicator lights of the wired remote control should light.

**NOTE:** If there is any abnormal phenomenon, please operate the unit under the direction of after-sales service.

(3). Check after the seasonal use

- 1). When the weather is fine, set the unit in the fan mode and keep running for half a day.
- 2). When the air conditioner is not going to be used for a long time, please switch off the power supply, the indicator light of the wired remote control will go out.

## 8. THE PARAMETER LIST OF DUCT TYPE INDOOR UNITS

Note:

The parameters are tested under the rated working condition;

Please refer to the actual parameters on the nameplate.

The cooling capacity is tested under the condition of outdoor temp.35 °C (dry bulb)/24 °C (wet bulb), indoor temp.27°C (dry bulb)/19°C (wet bulb).

The heating capacity is tested under the condition of outdoor temp.7 °C (dry bulb)/6 °C (wet bulb), indoor temp.20°C (dry bulb), excluding the heating capacity of auxiliary electric heater.

The noise value is tested in the anechoic chamber. The measuring point is 1.4m under the unit and the actual running the temp. will be higher due to the influence of environment.

## Model and Technical Specifications

Model	<b>80AH080J24</b>	<b>80AH100J24</b>
Function	Cooling and Heating	Cooling and Heating
Cooling Capacity(kw/Btuh)	22.4 / 76,400	28.0 / 95,500
Heating Capacity(kw/Btuh)	25.0 / 85,300	30.0 / 102,000
Air Flow Rate (m <sup>3</sup> /h/CFM)	4000/2353	4300/2530
Sound Level (dB (A) )	56	57
Input of Motor (kW)	1.2	1.35
Power Supply	208-230V / 1 phase / 60Hz	
Anti-electric Shock Protect	IP20	
Unit Dimensions (W×D×H)	1628x869x454 mm, 64"×34"×18-7/8"	
Package Dimensions (W×D×H)	1748x978x480mm, 69-1/8"×39-1/2"×19-1/8"	

Thank you for Choosing



---

[www.delta-dct.com](http://www.delta-dct.com)

